



## SERVINGS GUIDE

**This guideline applies to round cakes:**

Our cake tiers are usually **stacked** on top of each other. We do not offer cakes on cascading cake stands.

The individual tiers measure **at least 10-12cm in height**, sometimes even taller, to ensure their elegant and exclusive appearance.

For the size of **3D cakes** in the shape of a certain object, individual consultation is required.

In this table you can see how many tiers your cake will have and how many different cake flavours are possible:

Servings	Tiers	Cake Flavours
20-25	1 round cake	1 flavour
25-40	2 tiers	from 30 servings: up to 2 flavours
40-70	3 tiers	from 60 servings: up to 3 flavours
70-105	4 tiers	from 85 servings: up to 4 flavours
110-170	5 tiers	from 150 servings: up to 5 flavours

On the next page you will find a graphic representation of our cake sizes.

1 TIER

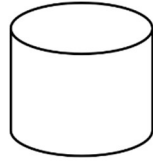

20 servings  
25 servings



1 cake flavour

2 TIERS

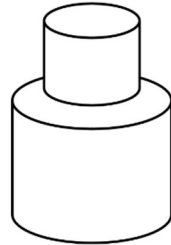

25 servings

30 servings  
35 servings  
40 servings



1 cake flavour  
Up to 2 cake flavours

3 TIERS

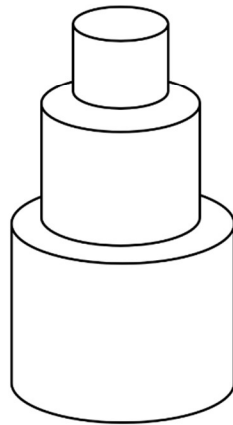

40 servings  
45 servings  
50 servings  
55 servings



Up to 2 cake flavours

60 servings  
65 servings  
70 servings



Up to 3 cake flavours

4 TIERS

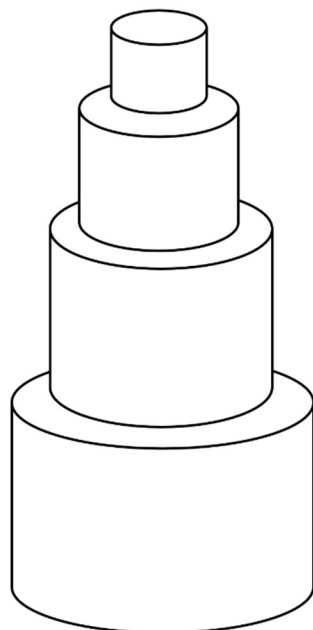

70 servings  
75 servings  
80 servings  
85 servings



Up to 3 cake flavours

90 servings  
95 servings  
100 servings  
105 servings



Up to 4 cake flavours